

Industrial heat pumps

March 2011



EMERSON[™]
Climate Technologies

Contents

Executive summary	2
Background	2
Coefficient of performance	3
Ammonia heat pump applications	3
Traditional heat pump.....	4
Chiller/heat pump	4
Scavenging heat pump	4
Example heat pump applications	5
140°F Poultry	5
160°F Beef	5
190°F Dairy	6
Economic analysis approach	7
Heat pump system design	8
Heat pump compressor	10
Heat exchanger considerations	12
Operational considerations	12
References	15
Contributors	15

Executive summary

Industrial refrigeration systems discard a significant quantity of heat to the atmosphere. Heat pumps can capture this wasted heat efficiently and use it to cut the fossil fuels burned to heat water. These industrial heat pumps are environmentally friendly and economical, allowing operators to make the most of their energy resources.

Ammonia heat pumps offer an owner a comprehensive green solution. They are environmental as the refrigerant is a natural refrigerant that has an ozone depletion potential (ODP) of zero and a global warming potential (GWP) less than 1.

Ammonia heat pumps provide conservation, by conserving the energy removed from the refrigeration system and transforming it so that it can be re-used and applied in a plant's water heating requirements. This source of energy is renewable as the heat is naturally occurring within food products and will be an available energy source for as long as we must refrigerate our food.

Ammonia heat pumps generate cash because the heat that is transformed from useless energy to useful energy provides savings. Even though the energy cost for each unit of energy is more for the heat pump's electric power supply, the heat pump saves cash because the effective Coefficient of Performance (COP), a ratio energy output to energy input, of the heat pump system is far superior to traditional water heating methods which cannot reach a COP greater than 1.

A secondary benefit, but of significant value, is that the heat pump diverts load away from evaporative condensers, allowing them to operate at lower pressures and conserving water and water treatment resources.

This paper addresses ammonia heat pump system challenges. Selecting the right heat pump compressor that balances first cost with operating efficiency and maintenance costs will ensure the best results from heat pump systems. The technology exists today to overcome the compressor challenges and deliver required temperatures using a natural and efficient refrigerant. With zero ozone depletion and a global warming potential less than one, ammonia is a natural choice for environmentally focused organizations, however, it is the efficiency of the refrigerant that makes it a natural choice in economic evaluations.

Background

Industrial food and beverage processors burn fossil fuels to heat water for processing and equipment sanitation. They also need mechanical refrigeration systems for processing and for cold storage. These refrigeration systems consume electricity. The heat absorbed by the refrigeration systems is usually discarded to the atmosphere as wasted heat. There is significant potential to harness the discarded heat and use it to produce hot water, thus reducing the fossil fuels used.

Heat pumps can capture rejected heat and put it to use for beneficial heating purposes. Recent developments in industrial screw compressors now enable heat pumps to deliver high quality hot water from 140°F (60°C) to 190°F (88°C).

Capturing the rejected heat of refrigeration systems is not a new concept. Although many means of heat recovery were used to pull out as much heat as possible from the discharge gases, ammonia heat pumps have not been viable until recently because of compressor limitations. Reciprocating compressors cannot deliver the water temperatures required by most processes and are employed mainly to supplement fossil fuel heating. To deliver the required temperatures, most heat pumps use Freon refrigerants with commercial refrigeration compressors. These systems have delivered attractive performance in northern Europe. While efforts are made to be environmentally friendly by selecting environmental Freon refrigerants such as R-134a (ODP=0, but GWP=1430 source: UNEP), a natural refrigerant such as ammonia would be a preferred environmental solution.

Heat pumps using ammonia refrigerant are extremely efficient and can deliver superior COP for similar operating conditions. Ammonia is a natural refrigerant with no ODP

and negligible GWP, and is widely used in large industrial refrigeration applications. Compressors are now available that can operate in conditions with high discharge pressures and large differential pressures that are required for ammonia heat pump applications. These compressors make it possible to exploit the full potential of the attractiveness that ammonia heat pumps represent.

Coefficient of performance

The coefficient of performance (COP) is unit-less index measure to compare two solutions, such as a comparison between a traditional boiler system and that of a heat pump. It is defined as the energy delivered divided by the energy consumed (note that heat and power energy must be converted to the same units to make the index unit-less).

For fossil fuel heating solutions, the theoretical maximum possible COP would be equal to 1, though this is not possible to reach in practical application. Most boilers cite efficiencies between 0.80 and 0.90, though there are some highly efficient designs that are above 90%. This cited efficiency is for a brand new boiler and efficiency will deteriorate through scaling and wear. Also, there are significant transmission losses in steam systems from loose fittings, service work, and condensation in the line that make the applied COP much lower than the original design of the boiler.

With a heat pump that uses refrigeration heat as its source (scavenging heat pump), the delivered energy is equal to the absorbed refrigeration heat plus the motor energy consumed by the heat pump compressor (note this requires that oil cooling and inlet de-superheating heat is usefully applied

to the water heating). The consumed energy is the motor energy, some of which is dissipated by the oil cooler, and the rest is absorbed in the ammonia gas flow. Because of this fact, the effective COP must be greater than 1 by definition:

$$\text{COP} = (\text{refrigeration heat} + \text{motor energy}) / \text{motor energy} = \text{refrigeration heat} / \text{motor energy} + 1$$

The effective COP will depend on the heat pump inlet pressure and the discharge pressure that is required to deliver the needed water temperature, just as it depends on suction and discharge pressures in traditional refrigeration applications. As shown in **Table 1**, there are several hot water temperatures required for the various applications in refrigeration for the food and beverage industries, but the COP is likely to range between 2 and 6 while a COP between 7 and 10 is possible for low compression ratio duties. The information in **Table 1** provides some sample COP's on single stage ammonia heat pump systems.

Ammonia heat pumps are much more efficient than traditional fossil fuel boilers. With an effective COP of 6 compared with a boiler system with a COP of 0.8, the heat pump provides 7.5 times more heat energy for each unit of energy input.

Ammonia heat pump applications

There are three typical categories of applications for industrial ammonia heat pumps that can replace fossil fuel burning systems. All three have significant opportunities to take advantage of the latest compressor capabilities to deliver value often sought but previously unobtainable.

Potential single stage heat pump COPs for hot water applications

Industry	Application	Water Temperature Required	Duration	Attainable Heat Pump COP
Beef Processing	Sanitation	150°F	Intermittent	7.2
Bottling	Bottle Warming	145°F	Continuous	7.6
Dairy	HTST Pasteurization	190°F	Intermittent	4.4
Dairy	Sanitation	155°F	Intermittent	6.7
General	Boiler Preheat	175°F	Continuous	5.3
Pork Processing	Sanitation	150°F	Intermittent	7.2
Poultry Processing	Sanitation	160°F	Intermittent	6.3
Poultry Processing	Scalding and Feather Removal	140°F	Continuous	8.2
Seafood Processing	Cooking Oil Heating	150°F	Continuous	7.2
Seafood Processing	Sanitation	160°F	Intermittent	6.3

Based on 95°F Host Condensing and 55°F entering water supply temperature

Table 1

Traditional heat pump

The first is a traditional heat pump using sources such as ground, air or water. While traditional heat pumps are the most widely applied through residential and commercial applications, industrial heat pumps offer a much larger scale. Industrial heat pumps applied to traditional heat pump applications deliver large scale heating requirements such as those applied for community heat in northern Europe. These large capacity heating systems absorb heat from large bodies of water, a large and consistent heat source, to continuously transform the “cold” low-grade heat source into the high temperature heating resource for the community. These systems offer an economically viable heating solution, but require long piping circuits to deliver the heat throughout the community. These long piping runs suffer heat and temperature degradation so high grade heat is required, much higher than many compressor designs can deliver. Even so, with compressor solutions now available to operate at these high pressures for high grade heating, this renewable energy source is attractive for its economic returns and the use of a renewable energy resource that does not deplete the ozone or have appreciable global warming impact. Although these projects are high profile and quite an interesting subject on their own, this is not the focus of this paper.

Chiller/heat pump

Another heat pump application applies the compressor simultaneously to beneficial cooling and heating needs.

The compressor discharge temperature is raised so that one compressor holds evaporator temperature for cooling and delivers heat through a heat pump system for medium grade heating requirements. The power consumed by the compressor is also used to raise the heat delivered by the heat pump system. Therefore the effective COP is doubled as compared to either a cooling only or heating only application. This is useful for applications that require both heating and cooling if the demands are correlated. Although there are many opportunities for dual chilling and heating, this paper will focus on the third application type, host system scavenging heat pumps.

Scavenging heat pump

This paper focuses on scavenging heat pump systems that use ammonia refrigeration systems as the heat source of the heat pump. The technology exists to apply heat pumps to large and small refrigeration systems, diverting the refrigeration system discharge around the condenser directly to the heat pump system. The solution can be added to existing systems as a stand-alone energy efficiency improvement that delivers quick payback while allowing the owner to cut carbon emissions.

Ideal for retrofit applications, the owner can offset the fossil fuel heating with heat already captured in the refrigeration system, cutting heating energy costs directly. Reducing the load on the condenser of the host system provides the indirect benefit of lowering the refrigeration system head pressure and improving refrigeration system efficiency.

Single stage scavenging ammonia heat pump system

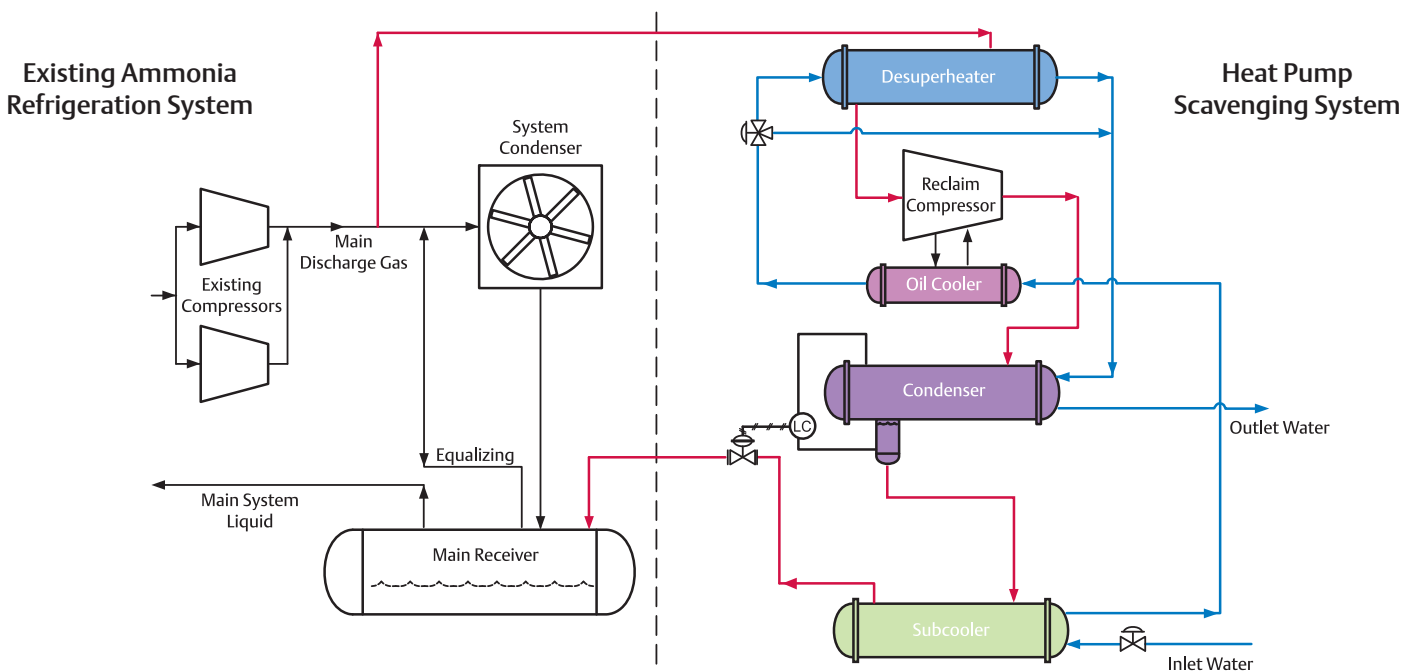

Figure 1

Example heat pump applications

Hot water demands vary among processing facilities, but three categories are the most common. The three applications are for 140°F, 160°F and 190°F delivered water temperatures. Three sample applications are described below, one for each temperature level.

140°F: Poultry processing scalding and feather removal

To remove the feathers and scald the chicken carcass skin, 140°F water is required. As part of a continuous process, this demand is constant as long as production is taking place making this a good application for a heat pump. The same process which generates a consistent demand for heating requires significant cooling that provides the source of heat for the heat pump in the same process. With a direct correlation for cooling demand and heating demand, the risk of inadequate heat source or imbalance between heating and cooling demand is low. For this reason, the heat pump can operate 18-20 hours a day with a fast payback. With the modest hot water temperature demand, a simple single stage heat pump with high COP performance is possible. See **Figure 1** for a layout of the sample system and the summary of performance figures below:

Required Refrigeration (Heat Source):	640 TR
Heat Delivered:	9,522 MBTUH
Entering Water Temperature (EWT)	65°F
Leaving Water Temperature (LWT)	140°F

Water Flow Rate (GPM)	250
Annual Heat Delivered:	56,603 MMBTU
Compressor Nominal Swept Volume:	600 CFM
HP Consumed:	538 HP
Location:	Texas
Electric Utility Rate:	\$0.075/kWH
Natural Gas Utility Rate:	\$0.022/kWH (\$6.5/MBTUH)
Installed Capital Investment:	\$750,000.
Heat Pump System COP:	7.0
Gas Boiler System COP:	0.83
Operating Hours per day:	19
Annual Operating Hours:	5,944
Annual Electric Op. Expense:	\$178,900.
Annual Avoided Gas Expense:	\$443,300.
Simple Payback:	2.8 Years

160°F: Beef processing equipment sanitation

The sanitation applications represent a significant hot water requirement at temperatures easily attainable with an ammonia heat pump, but two concerns arise from this application. The first is that the sanitation takes place between processing shifts so the heaviest refrigeration demand from processing is at minimum or diminishing levels. Most of these facilities have significant cold storage and freezing loads that can provide the source of refrigeration heat. Even so, the sanitation demand ranges between 4 and 8 hours, limiting the annual operating hours of the heat pump system and limiting the payback opportunities as a result.

Two-stage scavenging ammonia heat pump system

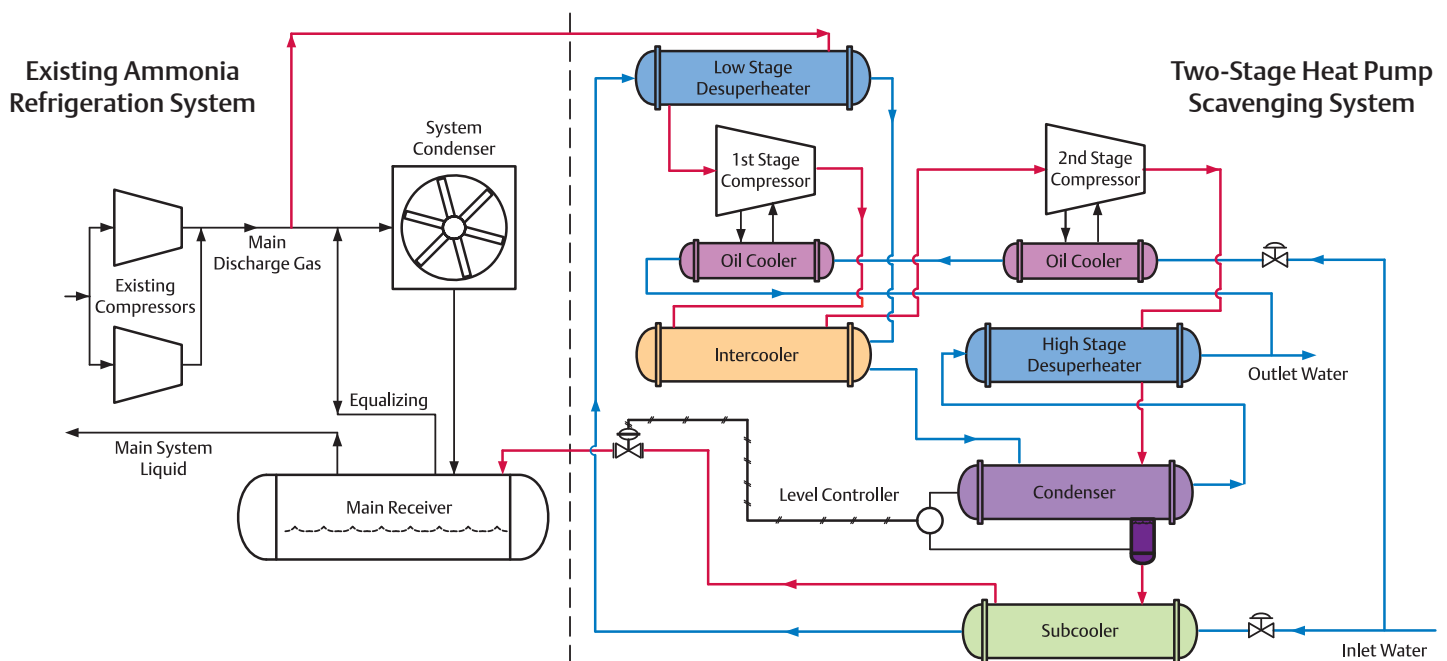

Figure 2

One alternative to overcome both of these issues is to use a storage tank so that the hot water supply can be built up throughout the day benefitting from the processing refrigeration load and allowing the heat pump system to operate for more hours in a day. This thermal storage strategy requires more capital for the storage tank and plant floor space for the tank. Though the former may be justified by the faster payback, available floor space may prohibit the thermal storage approach. Both approaches are summarized below. Note that for simplicity, identical system sizes were used so that the heat delivered by the thermal storage approach is 2.5 times greater because of the longer operating hours. A similar result would be obtained by using a system that is smaller to deliver the same heat. See **Figure 1** for a layout of the sample system and the summary of performance figures below:

Direct sanitation heat

Required Refrigeration (Heat Source):	675 TR
Heat Delivered:	10,275 MBTUH
Entering Water Temperature (EWT)	60°F
Leaving Water Temperature (LWT)	160°F
Water Flow Rate (GPM)	200
Annual Heat Delivered:	25,717 MMBTU
Compressor Nominal Swept Volume:	600 CFM
HP Consumed:	682 HP
Location:	Tennessee
Electric Utility Rate:	\$0.049/kWH
Natural Gas Utility Rate:	\$0.0243/kWH (\$7.12/MBTUH)
Installed Capital Investment:	\$700,000.
Heat Pump System COP:	5.9
Gas Boiler System COP:	0.96
Operating Hours per day:	8
Annual Operating Hours:	2,503
Annual Electric Op. Expense*:	\$62,435.
Annual Avoided Gas Expense:	\$190,735.
Simple Payback:	5.5 Years

* Ignores incremental maintenance costs for heat pump compressor versus a boiler which are considered to be inconsequential.

Thermal storage sanitation heat

Required Refrigeration (Heat Source):	675 TR
Heat Delivered:	10,275 MBTUH
Entering Water Temperature (EWT)	60°F
Leaving Water Temperature (LWT)	160°F
Water Flow Rate (GPM)	200
Annual Heat Delivered:	64,287 MMBTU
Compressor Nominal Swept Volume:	600 CFM
HP Consumed:	682 HP

Location:	Tennessee
Electric Utility Rate:	\$0.049/kWH
Natural Gas Utility Rate:	\$0.0243/kWH (\$7.12/MBTUH)
Installed Capital Investment:	\$800,000.
Heat Pump System COP:	5.9
Gas Boiler System COP:	0.96
Operating Hours per day:	20
Annual Operating Hours:	6,257
Annual Electric Op. Expense*:	\$156,100.
Annual Avoided Gas Expense:	\$476,835.
Simple Payback:	2.2 Years

* Ignores incremental maintenance costs for heat pump compressor versus a boiler which are considered to be inconsequential.

190°F: Dairy HTST pasteurization

The high temperature water demand for fluid dairy HTST pasteurization (High Temperature Short Time) process is similar to sanitation in that it is not a continuous demand, though it is required during processing so there is ample refrigeration to provide the heat source. A thermal storage approach is needed for reasonable payback periods. The operating discharge pressure required to deliver 190°F water will approach 750 psig, which will prohibit the use of most refrigeration reciprocating compressors and many screw compressors. Furthermore, with the high temperature of the demand, the compression ratio approaches 4.0 with a differential pressure at or above 600 psid. For these reasons, an efficient two-stage system is likely to be more attractive despite the higher first cost capital investment. Also, the high differential pressure can be managed easier in two stages than in one. The second stage heat pump compressor, which faces high suction pressures, must be able to operate at low internal compression ratios to remain below the compressor's discharge pressure limit. The following sums up the two-stage solution for this application. See **Figure 1** for a layout of the single stage solution and **Figure 2** for a layout of the two-stage solution:

Two-stage

Required Refrigeration (Heat Source):	650 TR
Heat Delivered:	9,670 MBTUH
Entering Water Temperature (EWT)	50°F
Leaving Water Temperature (LWT)	190°F
Water Flow Rate (GPM)	140
Annual Heat Delivered:	60,507 MMBTU
LS Compressor Nominal Swept Volume:	550 CFM
HS Compressor Nominal Swept Volume:	300 CFM

Total HP Consumed:	907 HP
Location:	Wisconsin
Electric Utility Rate:	\$0.06/kWH
Natural Gas Utility Rate:	\$0.0341/kWH (\$10.00/MBTUH)
Installed Capital Investment:	\$1,250,000
Heat Pump System COP:	4.2
Gas Boiler System COP:	0.85
Operating Hours per day:	20
Annual Operating Hours:	6,257
Annual Electric Op. Expense*:	\$254,200
Annual Avoided Gas Expense:	\$711,840
Simple Payback:	2.7 Years

* Ignores incremental maintenance costs for heat pump compressor versus a boiler which are considered to be inconsequential.

Economic analysis approach

In today's world, the cost and scarcity of energy resources demand that all projects and operations be viewed through the lens of energy conservation and efficient use. As environmental impacts take a central place in the public debate, fossil fuel energy becomes the focus of projects to cut consumption or improve energy efficiency. It seems only natural that an owner of a refrigeration system where so much heat energy is captured in the refrigeration cycle would seek ways to put that energy to use, rather than rejecting the energy to ambient without any beneficial use.

The payback period of the ammonia scavenging heat pump system depends on the heating demand and the local utility rates for gas and electricity. The ratios of typical utility rates in the US are shown in **Table 2**, showing which markets have the most favorable utility rates for heat pumps.

The other side of the equation is the COP, or heating system performance. Lower temperature water demands allow for lower compression ratios and better heat pump COP. Boiler system efficiencies will not vary greatly, but older boilers will have lower efficiencies that are further eroded through operating wear and tear. Also, the distribution system will have other steam losses that further lower the COP of the boiler system. When steam is leaked from the system, the steam carries with it high temperature vapor which has a large sensible heat input which is dwarfed by the heat of vaporization that is wasted when the steam is released. An accurate measure of the delivered COP of the boiler system is important in the economic analysis.

Although energy efficiency, cutting waste, and environmental concerns will support interest in heat pump projects, in the end it will be the economic analysis that determines if the project is done. As shown in **Table 1**, a COP of 2.5-10 is attainable in single stage operation depending on the quality of heat that is required. The fairly low COP delivered in single stage solutions for high quality heating applications can be improved dramatically through the application of two stage heat pump systems. Through heat pump system design and a flexible compressor solution, all the absorbed heat can be applied into the working fluid for maximum efficiency. The result is significantly lower energy consumption. For systems with consistent high heating requirements, the payback period will be 1-3 years. Even systems with intermittent heat-

Regional utility rates

Region	Electric (\$/kW)	Gas (\$/kW)	Electric/Gas Ratio
East North Central	0.0629	0.0157	4.00
East South Central	0.0534	0.0133	4.03
Mid Atlantic	0.0831	0.0236	3.51
Mountain	0.0565	0.0137	4.14
New England	0.1306	0.0284	4.61
Pacific Contiguous	0.0736	0.0160	4.61
Pacific Non-Contiguous	0.1910	0.0438	4.36
South Atlantic	0.0640	0.0176	3.65
West North Central	0.0537	0.0136	3.96
West South Central	0.0621	0.0139	4.48

Most/least favorable states

Most Favorable Utility Ratio States	Electric (\$/kW)	Gas (\$/kW)	Electric/Gas Ratio
Washington	0.0409	0.0283	1.44
Missouri	0.0463	0.0231	2.01
Nevada	0.0660	0.0275	2.40
Ohio	0.0586	0.0241	2.43
Montana	0.0563	0.0221	2.55
Least Favorable Utility Ratio States	Electric (\$/kW)	Gas (\$/kW)	Electric/Gas Ratio
Kansas	0.0586	0.0103	5.70
California	0.0981	0.0159	6.15
Texas	0.0670	0.0099	6.74
Connecticut	0.1529	0.0206	7.43
Alaska	0.1442	0.0098	14.72

Source: www.eia.doe.gov US Energy Information Administration, 2010 Report

Table 2

ing requirements can benefit with 4-6 year paybacks. The continued annuity of energy savings beyond the payback period will often justify the capital expenses by meeting a company's economic return requirements, and the environmental benefits further strengthen the justification.

Heat pump system design

Refrigeration system designers set operating conditions to increase compressor reliability and longevity by keeping discharge and oil temperatures low. But in a heat pump these temperatures are needed to deliver high-grade heat. A compressor's ability to tolerate these conditions reliably can define its suitability and applicability to heat pump systems. Because the goal is to deliver high temperature heat, high discharge temperatures are desirable and not cause for concern. Similarly, compressor designers and system engineers usually limit oil injection temperatures to 120-130°F to ensure high viscosity oil is available for bearing and compressor lubrication. With proper bearing and oil selection, the oil injection temperature can be raised significantly to nearly 200°F making it a much more useful heat source. For closed loop, high temperature heating applications where return water temperatures are above 130°F, the oil injection temperature can mean the difference between usefully applying oil cooler heat (for example, 190°F oil injection) and having to reject it without beneficial use (for example, 130°F oil injection). A compressor with lightly loaded bearings requires lower oil viscosity and allows for higher temperature oil injection. Besides putting the oil heat to beneficial use, the higher temperature oil injection allows the discharge gases to reach higher temperatures, as well, yielding higher quality heat pump compressor discharge heat content.

A final difference in heat pump design from refrigeration design is the many heat sources in a heat pump system. For refrigeration, the cooling is done in simple heat exchanger orientations of series configuration or occasionally parallel heat exchangers. In heat pump systems where there are

several temperature levels available (oil cooling, desuperheating, condensing, subcooling) the efficient delivery of heat from the system to the working fluid depends on the combination of heat exchangers. The performance of your heat pump system is defined by the efficient design of the heat capture, transfer and delivery making these systems more complex.

With scavenging heat pump systems, the heat pump source is the refrigeration system so there is a ready supply of ammonia vapor with its absorbed heat content. There are no required "low side" heat exchangers to absorb the source heat into the ammonia vapor. However, there are other heat exchangers and the ammonia compressors involved in the system design. These are described below.

Inlet gas desuperheater

In a scavenging system, the superheated vapor is supplied directly from the compressor discharge of the host refrigeration system. This superheat must be lowered and controlled to allow the compressor to operate reliably. This source of heat is low grade, defined by the host refrigeration system condensing pressure (85°F-95°F SCT). In some cases, this source of heat cannot be put to use because of the low temperatures involved, but regardless it only represents about 4-8% of the heat pump system heat available (See **Figure 3**).

High pressure desuperheater

The discharge from the heat pump compressors includes significant superheat above the saturated condensing temperatures. This is the highest temperature available in the heat pump system and can be used to "top off" the delivered water temperature to levels slightly above the heat pump condensing temperature (~2-4°F higher). In systems requiring moderate delivered water temperatures, the modest improvement in COP may not justify the added capital for a separate heat exchanger so the desuperheat and condensing can be combined into one exchanger.

For high temperature systems the high-pressure desuperheater is needed to reach the highest possible temperature for a given condensing temperature. It also limits the required compressor discharge and differential pressures by allowing the compressor to operate at a lower condensing pressure. Because it is the highest-grade heat in the system it can be extremely valuable, even though it only represents about 4-8% of the heat pump system heat available (See **Figure 3**).

Heat pump heat sources

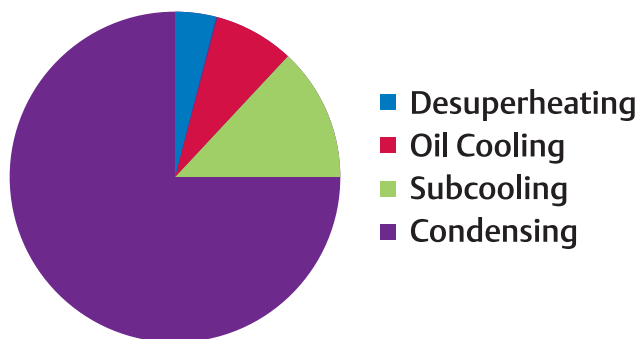

Figure 3

Heat pump condenser

The heat pump condenser delivers 65-75% of the heat to the working fluid. It is a high-grade heat source since it is on the high side of the heat pump system, and only the high-pressure desuperheater can offer higher-grade heat. The heat pump condenser sets the condensing temperature and defines how much the compressor must work to deliver the heat. With more condenser heat exchanger surface, the approach temperature is lowered allowing the compressor to operate at a lower discharge pressure and with lower consumed horsepower. The approach temperature will reach a practical limit when cutting compressor power does not justify the cost for more surface.

Compressor oil cooling

In a heat pump, rather than lowering the discharge temperature, the goal is to increase the heat content available with-

out compromising compressor performance or reliability. Selecting a compressor that allows higher discharge temperatures and higher oil injection temperatures is important to heat pump system performance. This source of heat is 4-6% of the total heat available (See Figure 3). An oil cooling heat exchanger is a required part of a heat pump and works to improve system performance.

Heat pump subcooler

High-pressure liquid must be returned to the host system from the heat pump condenser. Without subcooling, a large amount of flash gas is generated as the liquid is flashed down to the host system discharge pressure. Once the liquid pressure is reduced to the host system pressure, the liquid is returned to the host high-pressure receiver and the vapor to the vent line. The flashing provides no beneficial heating effect.

Pressure and temperature compressor limits

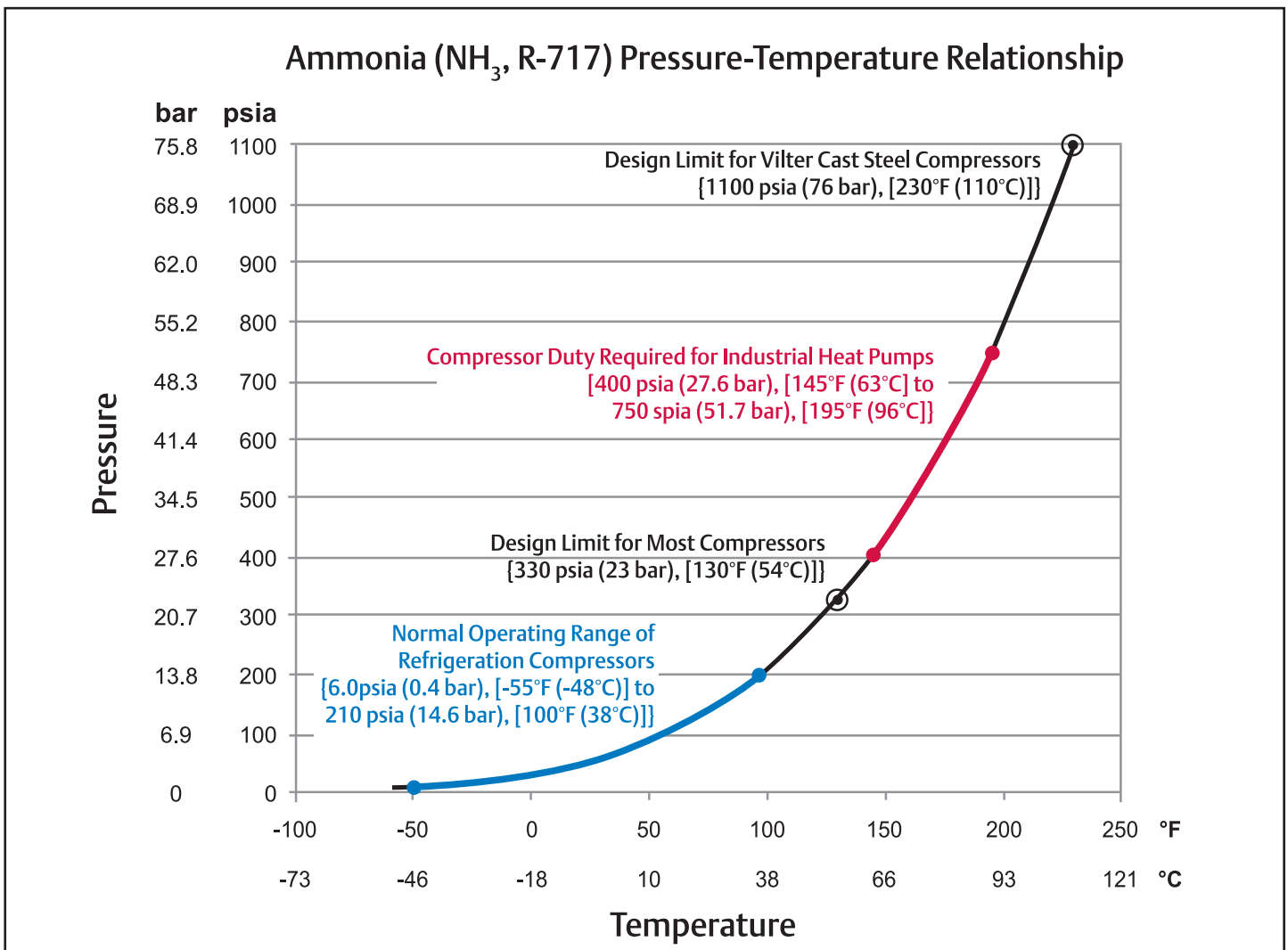

Figure 4

Flash gas can be eliminated with a subcooler. The heat available in a subcooler is of moderate grade as it starts at condensing temperatures, but approaches the host system discharge temperature in a sensible cooling process. The heat exchanger in the heat pump system provides significant heat pump COP improvement because it represents 8-15% of the total heat pump system heat available (See **Figure 3**).

Heat pump compressor

The compressor is the heart of the heat pump system. The capabilities of the compressor to withstand high discharge pressures, high differential pressures and tolerance of high discharge and oil injection temperatures have significant implications in heat pump system design. These challenges must be taken into consideration when selecting a compressor for an industrial heat pump application.

High discharge pressure

To take advantage of the heat absorbed in refrigeration, the heat pump compressor must be able to raise the pressure to levels that provide a proper quality of heat. This varies by operation and application.

There are several sources to extract the heat from the refrigeration system, however nearly 75% of the heat is locked up in the heat of condensation. Most ammonia compressors cannot reach the required temperatures of 140°F to 160°F, with equivalent saturation pressures between 365 psig and 475 psig. **Figure 4** shows the design limits of most commercially available refrigeration compressors. Higher discharge pressures are possible with proper casing materials and stronger designs.

High suction pressure

Ammonia heat pump compressors are positive displacement machines that raise the pressure of the vapor as a multiple of the suction pressure. The internal design defines the compressor operating envelope.

The refrigeration system discharge pressures that provide the source of the heat for a heat pump will range from 150-225 psig. As the minimum compression ratio for common ammonia screw compressors ranges between 2.8 and 3.4 (2.2-2.6 Volume Ratios), a compressor with 150 psig suction will deliver between 450 psig and 550 psig, regardless of the intended pressure required by the heating duty (See **Table 3**).

With high suction pressure and a minimum compression ratio, low minimum compression ratios and high discharge pressure limits are desirable attributes for a heat pump compressor.

When the heating duty requires even higher temperatures, multi-stage systems may be required with intermediate suction pressures higher than 250 psig.

High differential pressure

High suction pressure is related to the discharge pressure. The challenges the heat pump compressor faces are not limited to casing design capabilities, though.

The high suction pressure multiplied by the minimum achievable compression ratio of most compressor designs (> 2.75) generates a tremendous pressure differential between suction and discharge. The compressor internal design must absorb the great forces generated by this differential pressure. Although traditional refrigeration duties generate differential pressures of 150-200 psi, the heat pump systems have differential pressures between 300-600 psi. The internal forces faced by a heat pump compressor are two to four times that of a standard refrigeration compressor.

For a reciprocating compressor, the forces of differential pressure must be absorbed in the piston and cylinder design, and the entire drive mechanism. The wrist pins, crankshafts and bearings often cannot take this load. Smaller piston diameters can limit loads to the drive assembly, but the compressor still absorbs great forces resulting in heavy

Compressor vi range and minimum internal heat pump discharge pressure

Compressor	Vi Range	Minimum Compression Ratio (psig)	Heat Pump Suction Range (psig)	Minimum Compressor Discharge (psig)
Reciprocating	1.0-6.9	1.0	150-180	150-180
Twin Screw 1	2.6-5.8	3.4	150-180	550-653
Twin Screw 2	2.6-5.8	3.4	150-180	550-653
Twin Screw 3	2.2-5.0	2.8	150-180	441-524
Single Screw	1.2-7.0	1.3	150-180	194-232

Table 3

maintenance requirements and shorter compressor life.

For most screw compressors, there are three primary concerns with these high differential pressures. The first is the radial forces in which the differential pressure pushes from discharge to suction to drive the male and female screws of twin-screw compressors apart. With these forces doubled and tripled, the compressor design must be modified to accommodate larger bearings and wear and maintenance will also be higher.

The second is the thrust load pushing from discharge to suction. Although most screw compressors are designed with large bearings to absorb this thrust force, it is magnified two to four times for heat pump compressors.

The third concern is also a common one facing refrigeration compressors, particularly those with high compression ratios where the differential pressure is greatest for refrigeration applications. Because the rotors are supported on their ends with differential pressure pushing in the middle, the rigidity of the rotor can be a concern. If the rigidity of the rotor is not enough to handle these differential pressures, rotor deflection can lead to failure. For this reason, the compressor design includes specific limitations for differential pressures for a given compressor design. As rotors become longer for a given rotor diameter, they become more efficient and economical, but also more prone to mid-rotor deflection limiting their differential pressure application range.

Single screw compressors have an inherent design advantage that overcome these three concerns. First, as the name indicates, single screw compressors are composed a single rotor, rather than twin rotors, so mid-rotor deflection is not a possibility in single screws. Second, suction gas is vented to the discharge side of the compressor, thus eliminating thrust loads. Finally, gas is discharged radially and simultaneously on opposite sides of the rotor, thus eliminating radial forces. This balanced design approach enables single screw compressors to operate reliably at high suction pressures and high differential pressures.

High discharge temperature

Raising the oil injection temperature and allowing the discharge temperature to rise improves heat pump system efficiency. Reciprocating compressors have lower discharge temperature limits, but screw compressors are oil flooded and can operate at higher discharge pressures without exceeding maximum oil temperature limits.

The oil cooling of the screw compressor needs to be applied

to useful heating of the heat pump fluid for higher COP. But for closed loop systems with high heat pump fluid return temperatures, the oil heat of rejection cannot be used without elevating the oil injection temperatures to levels well above those faced in traditional refrigeration duties which makes the oil viscosity a concern. The machine's minimum oil viscosity requirements and the selected oil will define the limits for a heat pump compressor.

For compressors that require higher viscosity oil to operate at high temperatures, issues may arise between the oil requirements of the heat pump system and that of the host refrigeration system. For low temperature refrigeration systems, high viscosity oil will present problems to the refrigeration system on the low side of the host refrigeration system because the viscous oil will be difficult to remove at low temperatures. Because of oil compatibility and oil management issues, having different oils in the host refrigeration system from that in the heat pump system is difficult to manage. When possible, select a heat pump compressor in which the refrigeration system oil provides adequate viscosity for the heat pump compressor at high discharge temperatures.

High mass flow

The mass flow through a heat pump compressor is high because of the density of the suction vapors at the high pressures. A positive displacement compressor is designed to deliver a specific volumetric flow rate and the mass flow fluctuates with the suction gas density. In heat pump applications, the suction densities range between 2.5 and 6 times that of traditional refrigeration duty compressors. Refrig-

High pressure single screw compressor

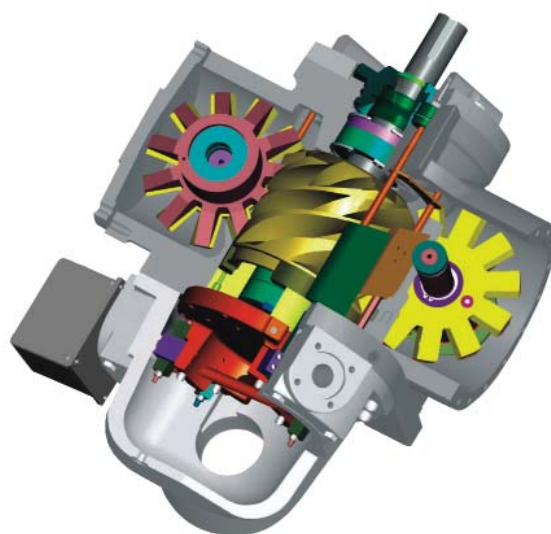

Figure 5

eration compressors are not designed to handle these high mass flows. Without a suitable high mass flow design, this flow will lead to significant internal pressure losses taxing the compressor efficiency and sapping the COP of the heat pump system. The heat pump compressor must be designed for high mass flow rates.

Maintenance costs

In a rigorous heat pump duty compressor application, the forces imparted on the compressor can require significant maintenance to operate in these conditions. With forces and mass flow many multiples of those faced in refrigeration duties, the frequency and cost of maintaining the compressor will face similar multiples. As testimony to this, one reciprocating compressor manufacturer applying compressors for a low temperature (~140°F) heat pump system required that the 10,000-hour (when operated at normal refrigeration conditions) maintenance overhaul is performed after just 2,000 hours (for more rigorous heat pump duties).

From drive system forces, bearing replacement and lubrication concerns, and valve wear and tear, the maintenance concerns facing a reciprocating compressor in this duty are significant. Single screw compressors will face fewer maintenance issues. The greater forces yield heavier bearing loads and greater concerns for oil viscosity protection. Maintenance costs should be considered in the evaluation and selection of the heat pump compressor.

Heat exchanger considerations

The heat exchangers of a scavenging heat pump system deliver the heat from the heat pump to the working fluid. Heat exchangers can be shell and tube or plate type. Because of the high pressures, a plate and shell type heat exchanger is more common than a plate and frame type when plate exchangers are used.

A plate type heat exchanger offers close approach temperatures because of their high heat transfer rates and flow circuiting flexibility. This allows the maximum heat to be drawn out of the refrigerant and lowers the compression ratio required with a close approach condenser design. The compact design of plate type heat exchangers also simplifies package designs. Since there are several heat exchangers in a heat pump system, smaller heat exchangers can improve the package layout.

Heat exchangers must withstand high refrigerant pressures and thermal stresses. If the heat pump will see intermittent use, cyclic thermal stresses will tax the heat exchanger de-

sign. Some plate type exchangers are not designed to handle these pressures and thermal stresses. Also, with the elevated temperature of the heating system, water side scaling is an issue. When the flow stops and all the surfaces remain warm, the scale buildup on all surfaces is accelerated requiring more frequent cleaning. Plate type heat exchangers are not easily cleaned. Chemical flushing may be used, but over time some fouling may reduce the effectiveness of the heat exchanger.

Shell and tube heat exchangers offer an alternative to the plate type. This design is accessible for cleaning and accommodates thermal expansion and contraction. But these heat exchangers are not able to reach the same approach temperature that a plate type exchanger can reach which diminishes the system efficiency and achievable COP. Also, these heat exchangers are much larger which impacts the package design.

The decisions on heat exchanger design affect system performance. Because of the detrimental effect scaling will have on the system performance, cleaning concerns may dictate that shell and tube heat exchangers are selected for the application. If, however, a successful scale management strategy can be employed, the benefits of plate designs will provide performance advantages. Regardless of the type of heat exchanger selected, lowering the approach temperatures will enhance the system performance. With close approach heat exchanger designs, the achievable COP is significantly improved. If the application requires high water temperature delivery such that the compressor must operate at or near its design limits, the closer approach on the condenser heat exchanger can allow the system to reach higher water temperature delivery within its operational limits. Close approach, while desirable for performance reasons, also comes at a cost, as the heat exchanger requires greater surface.

Operational considerations

Several operational issues should be taken into account when considering an ammonia scavenging heat pump system. These issues are described along with proposed solutions for planning such a project.

Piping

Hot water piping requires larger pipe sizes than steam piping, usually 1-2 pipe sizes larger. Steam and hot water lines should be insulated to retain the heat generated until delivery.

Oil management

In a scavenging system, the vapor from the host system that is discharged from refrigeration compressors is pulled directly into the heat pump system by those compressors. The liquid that is condensed in the heat pump condenser is returned to the host system. As in a stand-alone refrigeration system, oil management must be considered for return to the compressors and removal from vessels and heat exchangers. The vapor that is introduced into the heat pump system carries oil from that system with it and the liquid that is returned will have some oil entrained, just as liquid in the host refrigeration system carries some oil to the low side. For this reason, the oil of a scavenging heat pump system should be the same as that of its host refrigeration system to reduce oil management issues. When the oils are the same, oil can be collected in oil pots at several points in the heat pump system and returned to the compressor or to the host system using hot gas pressure.

Non-condensable purging

In refrigeration systems any non-condensibles introduced into the system will migrate to the high pressure points of the system. Purging systems automatically remove these from the points where non-condensibles are likely to accumulate. With a scavenging heat pump system, the condenser and receiver of the host refrigeration system are no longer the high pressure points of the system. Purging at these locations is still recommended as much of the flow will continue to go to the system condensers, but the non-condensibles are likely to follow the diverted gas to the heat pump system seeking the high pressure points of the system. An ideal solution would be to apply automatic purge system to the heat pump system, but these systems have not yet been approved for high-pressure heat pumps. Manual purging is one option, but must be considered for safety. Another design approach is to continuously bleed some pressure from the high stage of the heat pump system back to the condenser purge point of the host system. It can be employed by either using a small line for constant flow back to the host system, or a solenoid valve that is timed for the purge cycle.

Potable water

Most applications for food processors require that the heated water be suitable for potable consumption. A separate circulation is required for these applications so that the heat pump system heats up glycol or treated water that is used

in a heat exchanger to deliver the heat to the process fluid for the food processing application demanding the heat. Besides the water quality concerns, a separate heat exchanger prevents refrigerant from leaking into the process operating fluid. Although this additional heat exchanger reduces system efficiency and introduces added capital expense for the exchanger, the capital cost is mitigated, as the piping and heat exchanger material costs are lower when glycol is used in the heat pump system rather than water. The required material for the heat pump system with a glycol working fluid can be carbon steel rather than 316 stainless steel.

Scaling issues

Scale is unavoidable, but its impact can be mitigated when employing closed loop systems. System piping and heat exchangers should be designed for cleanability. Plate type heat exchangers should be gasketed and allow for plate removal for cleaning and reassembly provided they meet operating pressure requirements. While the high temperatures of the water circulating systems will aggravate the scaling issues, these temperatures and issues are already addressed in boiler systems. Though different from boiler systems, hot water systems are not expected to require more costly water treatment measures. But it is likely to require unique application considerations. Consultation with plant and vendor water treatment experts is recommended.

Corrosion

Corrosion inhibition is required. Water can be among the most corrosive of working fluids. For open systems where air is introduced to the water, the issue is magnified many times. The working fluid in open systems is corrosive, requiring 316 series stainless steel piping and heat exchangers. Carbon steel materials cannot survive in this corrosive environment. Even closed loop water systems may require stainless steel piping, if sufficient corrosion inhibitors cannot be added to the recirculated water. When the heat pump system acts as a secondary heating for the primary processing fluid, it uses glycol, with its corrosion inhibitors, to reduce the corrosion concern and allow lower cost carbon steel piping.

Stress corrosion

Stress corrosion is a complex type of corrosion to which such heat pump systems are vulnerable. Low tensile strength materials can cut the risk for stress corrosion failures.

Balance heat/cool

The heat pump system converts the heat absorbed in refrigeration to a level that allows beneficial heating. Without the source of heat, there will not be adequate suction vapor for the heat pump system. It is imperative to consider the load profile of the refrigeration system as mapped over the load profile of the heating. Applications with a strong correlation between heating and cooling loads are well suited to heat pumps systems because when more heating is required, the heat source is also at its maximum. But for applications when the cooling is at its minimum when heating requirements are the greatest, there is more of a challenge. The entire load profile should be evaluated to ensure that adequate heat is always absorbed in refrigeration to supply the heat pump system. If it is not, then the heat pump system may need to be smaller with auxiliary heating.

Inconsistent demand

The demand for heating is often inconsistent or cyclical throughout the day, week, or season. If demand is inconsistent, a thermal storage system can spread the heat load over an entire day. A benefit is that the heat pump system can be smaller and operating savings are accumulated over more hours with a faster payback period.

System control

The control of the heat pump system depends on variable inputs and output demands. Many factors have to be taken into account to design a system control strategy, including suction supply temperatures and pressures, discharge pressure, water temperature and flow rate. The right control variable must be identified which will allow the system to load up the compressor as needed to deliver the required water temperature.

Conclusions

- Heat pumps can capture industrial waste heat efficiently and reduce fuel use.
- Ammonia heat pumps operate at a much higher coefficient of performance (COP) than boilers.
- The right heat pump compressor balances first cost with operating efficiency and maintenance costs.
- Recent developments in industrial screw compressors now enable heat pumps to deliver high quality hot water up to 190°F (88°C).

References:

1. http://ozone.unep.org/teap/Reports/RTOC/rtoc_assessment_report06.pdf UNEP, Montreal Protocol on Substances that Deplete the Ozone Layer, 2006 Report of the Refrigeration, Air Conditioning and Heat Pumps Technical Options Committee.
2. http://www.zogg-engineering.ch/Publi/IEA_HPC08_Zogg.pdf "History of Heat Pumps", Zogg, 2008
3. [Pearson, 2010] IIR, Sustainability and the Cold Chain "District Heating, District Cooling, and Desalination Using Ammonia Heat Pumps."
4. https://iiar.org/aar/aar_green1.cfm IIAR, "Ammonia: The Natural Refrigerant of Choice (An IIAR Green Paper)"
5. http://www.eia.doe.gov/dnav/ng/ng_pri_sum_dcunus_m.htm US Energy Information Administration (EIA) "Natural Gas Prices"
6. http://www.eia.doe.gov/electricity/epm/table5_6_a.html US EIA "Average Retail Price of Electricity to Ultimate Customers by End Use Sector, by State"
7. <https://www.iiar.org/condenser/11-2009.pdf> IIAR, "Industrial Heat Pumps: The Renewing of Rejected Heat".
8. "Go Green With Ammonia Heat Pumps", by John Flynn, presented at RETA 2010.

Contributors

John Flynn has worked in industrial refrigeration for nearly 20 years. His career areas include sales and marketing, product development, and sales management. As Director of Sales for Vilter Manufacturing, LLC, a business of Emerson Climate Technologies, John is responsible for identifying and executing growth initiatives throughout all of the domestic and international markets served utilizing compression equipment serving industrial refrigeration and oil and gas applications. In addition to sales and market development initiatives, John is responsible for implementing the infrastructure required to support new markets and industries served in collaboration with the regional Emerson Climate offices.

Sam Gladis has had a career in industrial refrigeration for more than 25 years. With a career focus on energy conservation, Sam has been involved in the design, installation and commissioning of energy-efficient industrial refrigeration systems for food processing, cold storage facilities, and thermal storage systems. As Director of Marketing for Vilter Manufacturing LLC, a business of Emerson Climate Technologies, Sam guided industrial refrigeration compressor products, responding to shifts in customer and market needs. Mr. Gladis serves as Business Director-Heat Pumps. In this role, Sam advances industry's focus on energy efficiency and reclaiming the waste heat of refrigeration over a wide spectrum of markets and applications.

Brian Buynacek has 16 years of industrial marketing experience, including positions in marketing product management, key account management, and application and manufacturing engineering. He is a registered professional engineer in the state of Ohio and a LEED-AP. As a senior consultant with Emerson's Design Services Network, he has driven more than 100 key marketing and engineering projects in commercial and industrial refrigeration, gas compression, and manufacturing.

EmersonClimate.com