

Copeland™ Digital Outdoor Refrigeration Unit

X-Line Series

June 9, 2020

Julie Havenar

Product Manager, Condensing Units
Emerson



Speaker



Julie Havenar

Product Manager, Condensing Units
Emerson

Julie Havenar joined Emerson in 2015. As the company's product manager for condensing units, she focuses her efforts on the development and marketing of condensing units to serve both the foodservice and food retail markets. Prior to her role in product management, she has held roles in strategic pricing and market analysis.

Julie earned a bachelor's degree in marketing and decision sciences from Miami University.

Agenda

Decentralized Condensing Units

Copeland™ Digital Outdoor Refrigeration Unit

- Digital Technology
- Applications
- Features and Benefits

Field Test: X-Line Digital

Additional Materials and Information

Q&A Session



Decentralized Condensing Units

Refrigeration Architectures

New and Remodel Choices



Traditional HFC Centralized DX Rack

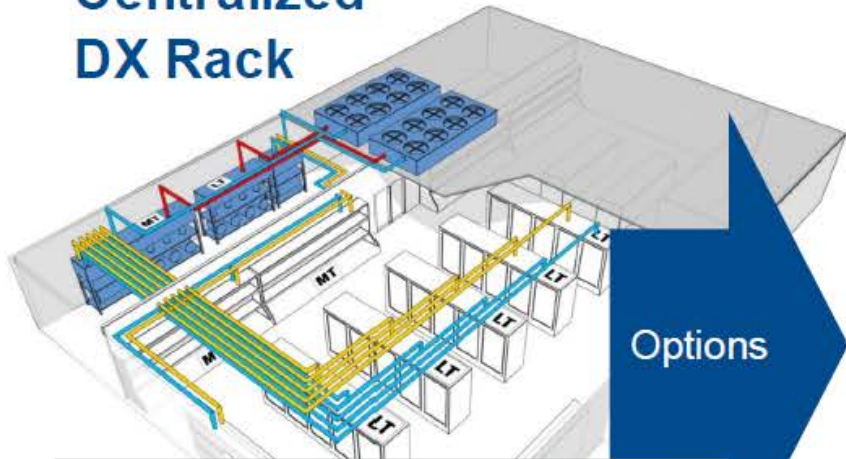

Options

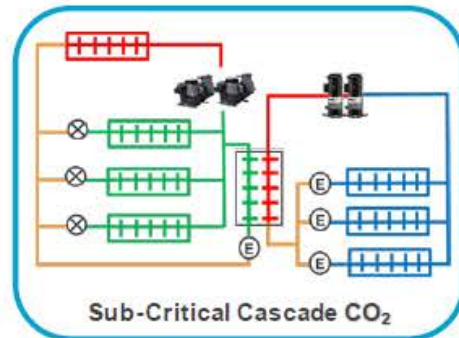
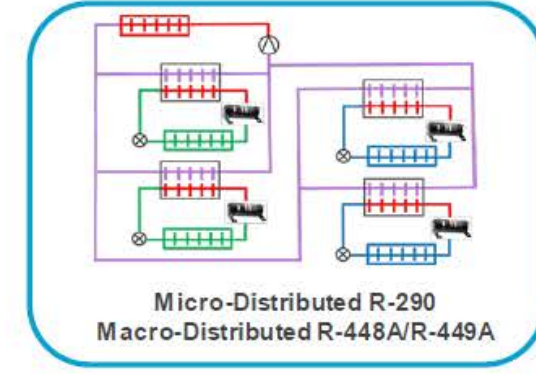
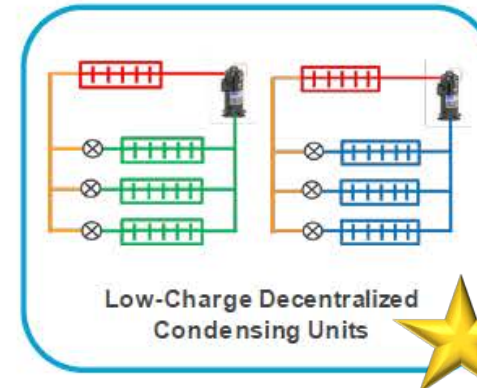
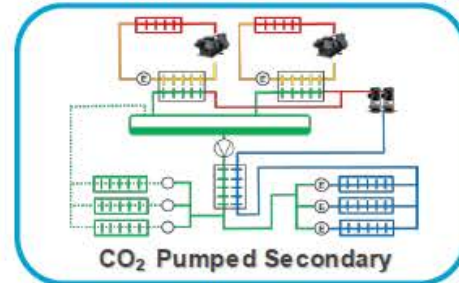
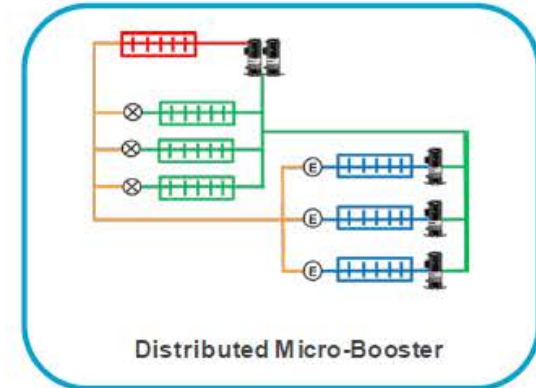
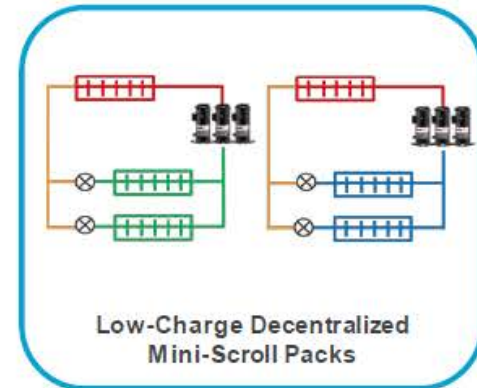
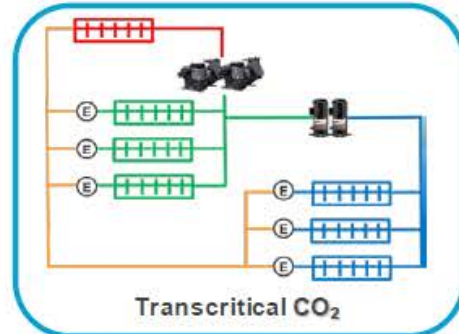

EMERSON

Future Refrigeration
Architectures for Meeting
Refrigerant Regulations

E360 Webinar • May 5, 2020

Andre Patenaude
Director — Solutions Integration
Emerson

Diego Marafon
Refrigeration Scroll Product Manager
Emerson



Benefits of Decentralized Condensing Units

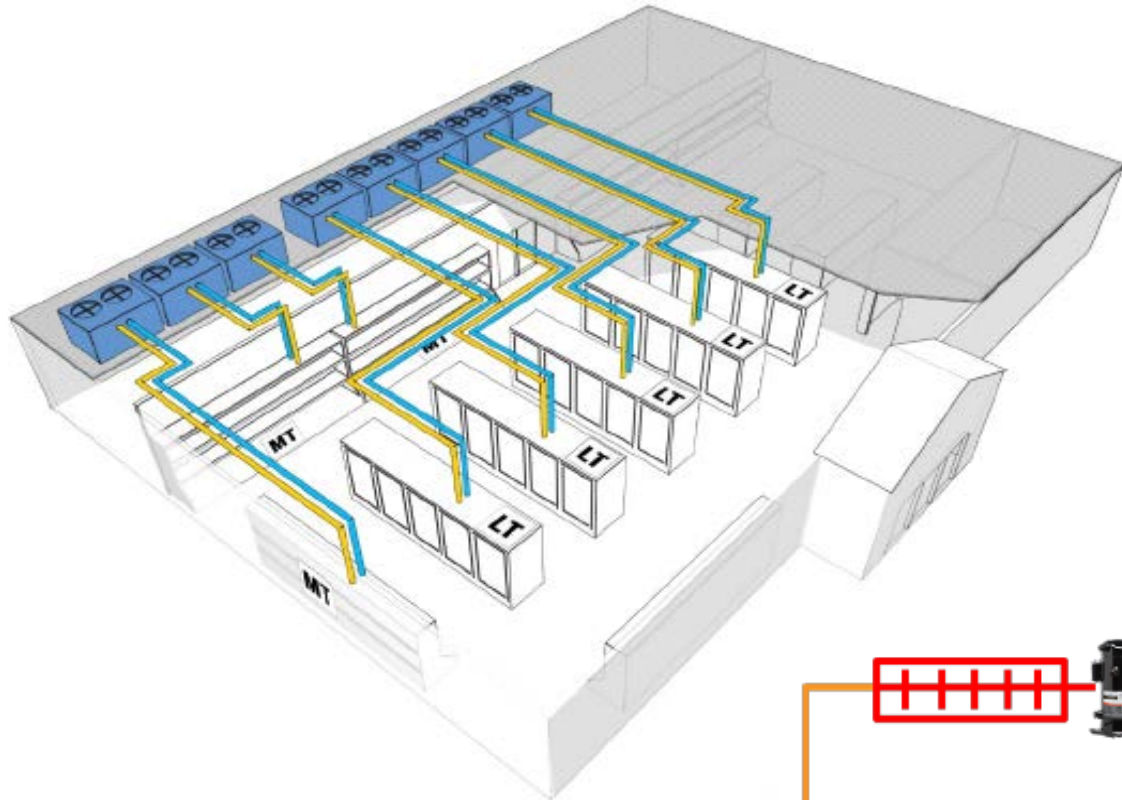

- Simple architecture; easy to implement
- Removes heat and sound from the building
- No water loops/pump skids necessary for air-cooled units
- Flexibility for load expansion and retrofits

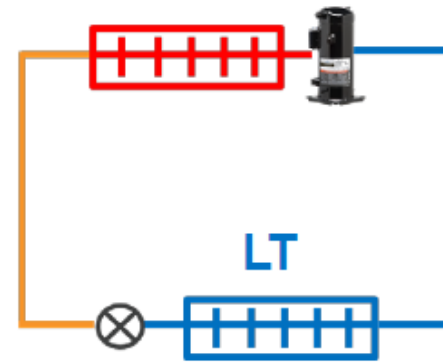
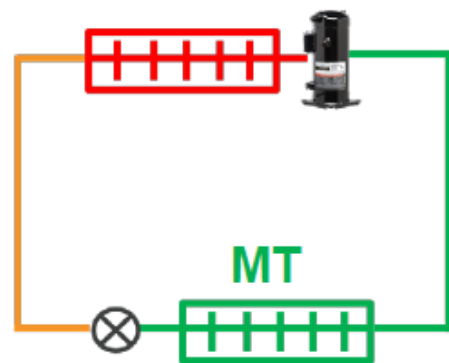

Limitations on Traditional Decentralized Condensing Units

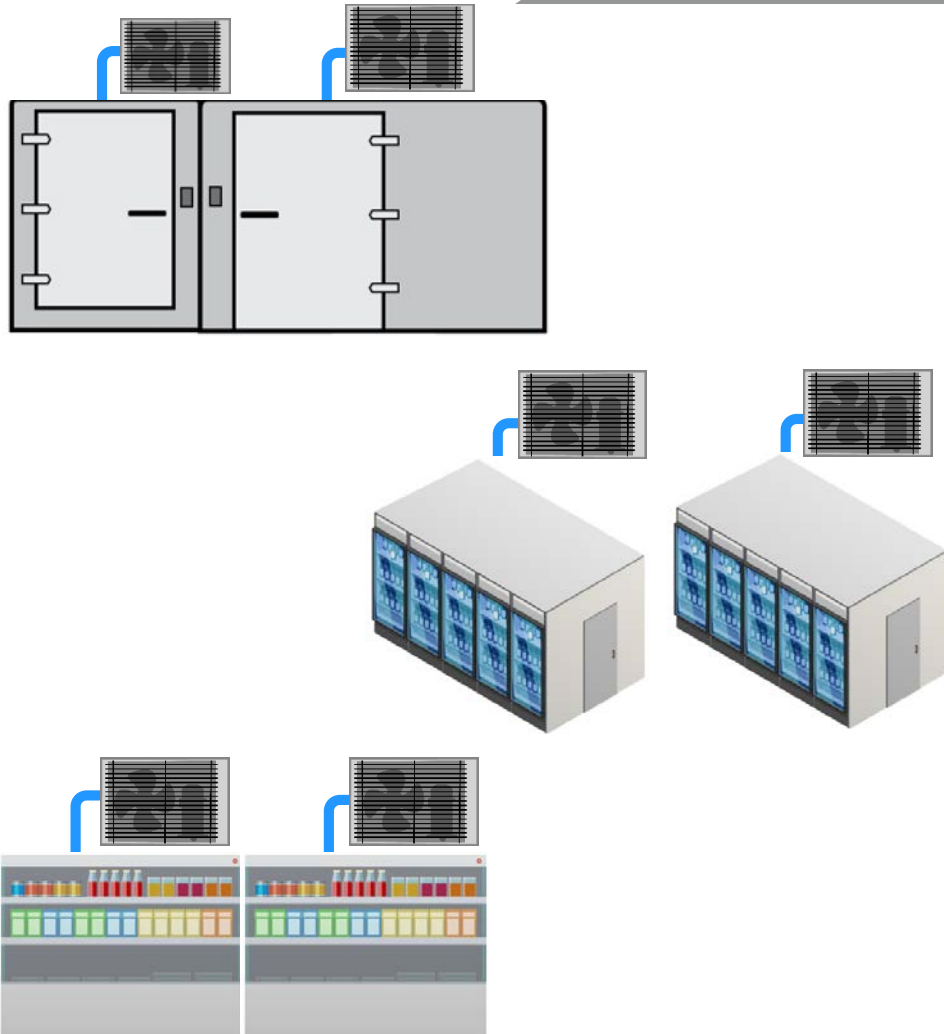

- Mechanical controls
- No remote communication
- No onboard diagnostic
- Square metal outdoor enclosure restricts mounting options
- Single-speed, on/off fan cycling controls
- Lack of system protections
- Single units required for every load
- Each unit individually field wired and piped per case or walk-in box

X-Line Series Features and Benefits



**Relaunched
in 2016**



SLIM
PROFILE



CONNECTIVITY



QUIET



PROTECTION



ENERGY
EFFICIENT



AWEF
COMPLIANT

¾ to 6 HP Medium-Temp. → 134a 404A 407A 407C 448A 449A
¾ to 6 HP Low-Temp. → 404A 407A 407C 448A 449A

X-Line Series Features and Benefits



Larger condenser coils

Increase efficiency;
Coated for weather

Variable-speed fan motor control

Quiet and efficient head
pressure control

Heated and insulated receiver

Allows operation in low-ambient situations

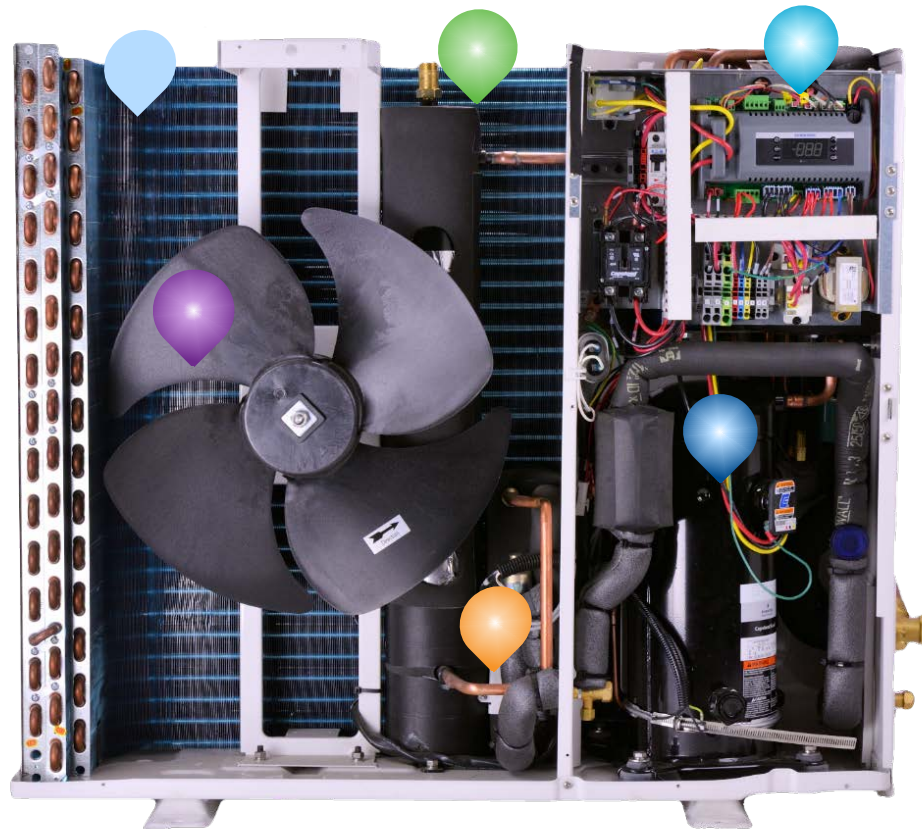

Electronic controls

Offer greater reliability than traditional
mechanical controls;
Built-in protection and diagnostics;
Bump start feature

Copeland scroll digital compressor technology

Provides the most reliable, highest-efficiency
compression technology available

Enhanced vapor injection

Improves capacity and energy efficiency
(low-temp., fixed-speed only)

X-Line Series Communications



XWEB Internet Gateway



Site Supervisor

Available to end users through retail solutions



Remote “off-site” visibility and control



E2 Site Control

Existing installations
V4.08



Copeland™ Digital Outdoor Refrigeration Unit

X-Line Series

Copeland Digital Outdoor Refrigeration Unit, X-Line Series



NEW!

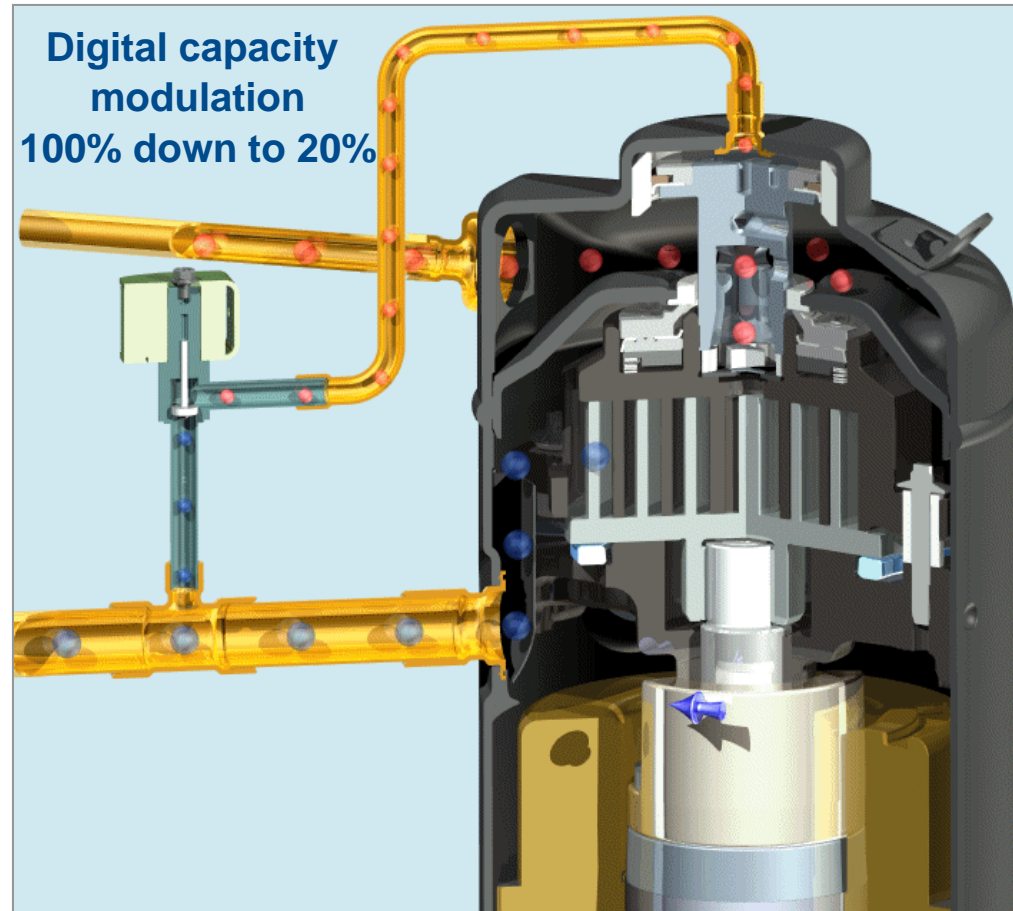

What Is Digital Modulation?

- Copeland digital technology is fundamentally different from inverter-based modulation.
- The capacity modulation of the digital compressor is achieved by averaging the time between a “loaded state” and “unloaded state”.
- It is unique, reliable and very simple to apply.

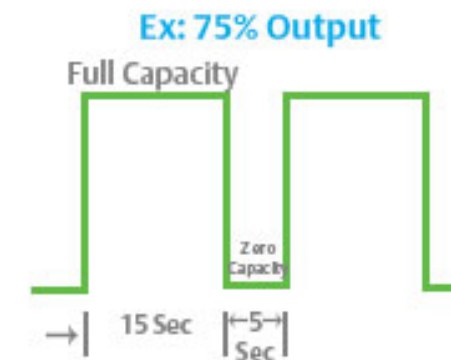
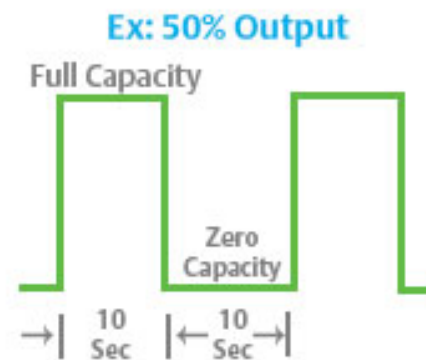
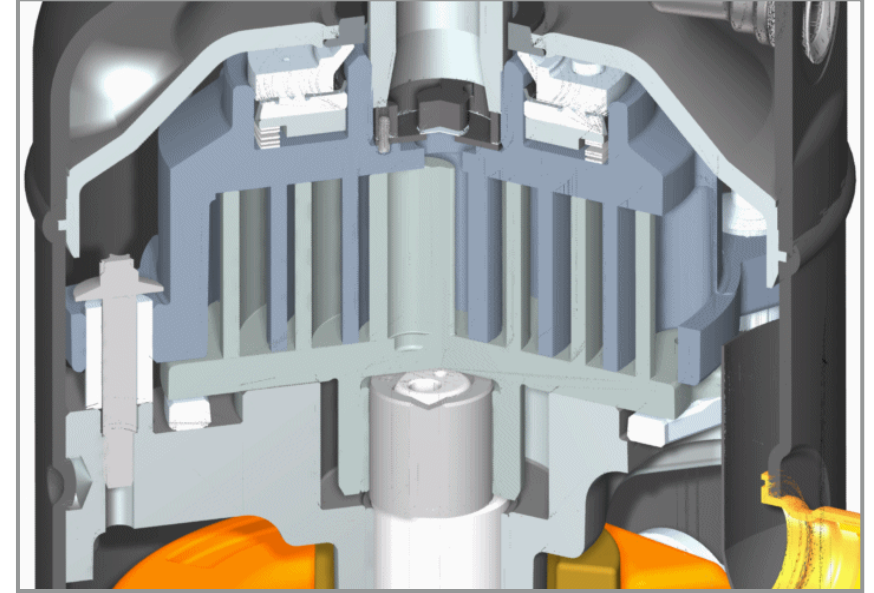
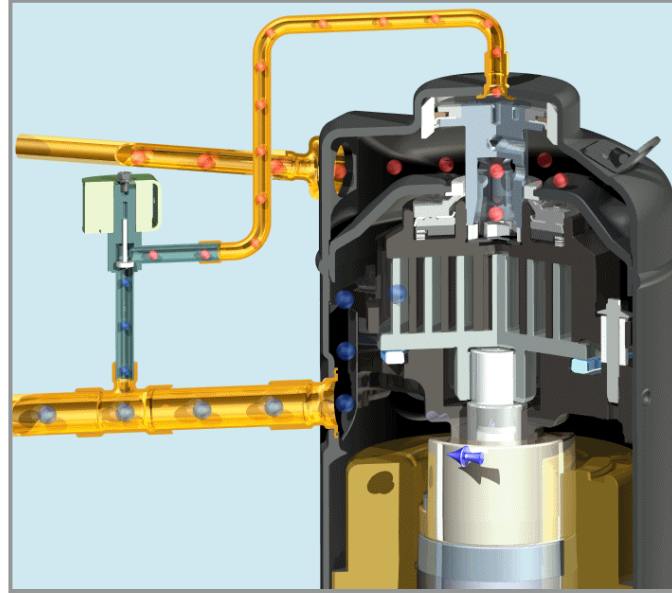

Applications



Display Cases • Walk-In Coolers • Food Preparation • Process Chillers

Convenience Stores



Restaurants

Supermarkets



Industrial

Features and Benefits



Digital, Multiplexing Technology

Multiple Cases per Unit



Capacity Range (95° Ambient)

Medium Temp R-404A +25°F evap																											
XFAM-030D																											
XFAM-040D																											
XFAM-050D																											
XFAM-060D																											
	0	2	4	6	8	10	12	14	16	18	20	22	24	26	28	30	32	34	36	38	40	42	44	46	48	50	52

Refrigeration Load (kBTU/hr)



Features and Benefits



Installation Benefits

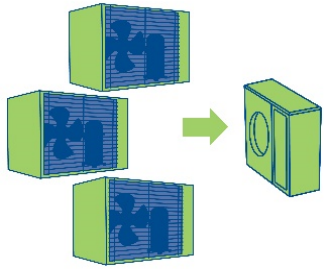

Fewer units to install and maintain

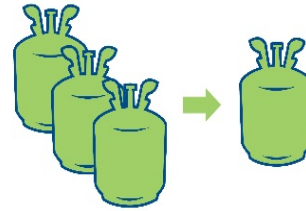

Reduced refrigerant charge and line sets



Lightweight and flexible installation options



Reduced costly call-backs with advanced diagnostics



Simple and quick commissioning

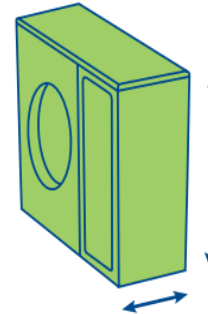

Slim chassis and easy installation

Features and Benefits



Operational Benefits



Advanced diagnostics

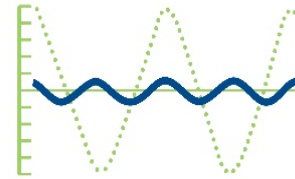

Tight temperature precision



Energy efficient



Ultra-quiet operation



Field Test: X-Line Digital

Premier Steakhouse

Field Test — Preinstall



Pain Points

- Aging architecture; needed to be upgraded
- Wanted to reduce water and energy consumption
- Did not want indoor air-cooled to avoid heat in the kitchen
- Needed more space in kitchen hallway
- Very limited available space on roof



Field Test — Results



X-Line Installation

1 digital 6 HP MT CDU serves 8 evaporators:

- Kitchen under-counters
- Meat aging walk-in box
- Meat prep room
- Meat walk-in box
- 3-door bar refrigerator
- 2-door, reach-in refrigerator

3 additional X-Lines:

- LT 2 HP fixed: walk-in freezer
- MT 6 HP fixed: walk-in cooler
- MT 6 HP fixed: walk-in cooler

Results

- Significant reduction in water usage; prior system used Olympic-size pool per day
- Eliminated condensing units from hallway to allow for more storage
- Fewer refrigeration condensing units to maintain
- 50% reduction in refrigerant charge (<50 lbs.)
- Highly flexible load matching, 20–100%
- Precise setting and tight control over case and box temperatures
- Energy-efficiency improvements

Specific Contractor Feedback

- Controls humidity of meat room more precisely
- Keeps suction pressures even; evaps don't ice
- Reduced on/off cycles
- CoreSense™ diagnostic — protecting highly valuable product — can watch system on phone through Site Supervisor

Additional Materials and Information

Additional Materials



Copeland™ Digital Outdoor Refrigeration Unit X-Line Series

The compact solution for continuous capacity modulation

The Copeland Digital Outdoor Refrigeration Unit sets a new standard for energy efficiency, reliability, and installation flexibility. With 20-100% modulation now available and expanded refrigerant approvals, its industry-leading on-board diagnostics and system protection can help optimize operational efficiency and deliver peace of mind to any end user. Digital X-Line units are available for applications commonly found in today's food service and food retail establishments.

Designed with three factors in mind

Energy Efficiency

Modulating scroll compressor technology, variable speed fan motors, large capacity condenser coils, and advanced control algorithms, work together to significantly reduce energy consumption.

Reliability

Equipment reliability is greatly enhanced by combining the proven reliability of Copeland scroll compressors with advanced on-board diagnostics and system protection technology. Each unit has built-in diagnostics and protection that can alert and record alarms independently or communicate with building management systems.

Flexibility

The ultra-quiet variable-speed fan motor significantly reduces exterior sound levels and is combined with a lightweight weather-resistant cabinet, slim footprint, and optional wall mounting capability to deliver unmatched installation flexibility.

Refrigeration Applications

The perfect solution for applications with wide load variation

- Coolers
- Display Cases
- Industrial Process Chillers
- Refrigerated Air-Dryers



“ We replaced multiple outdoor condensing units with a Copeland Digital Outdoor Refrigeration Unit. The unit cycles less and we see much tighter case temperature control. ”

— Small format grocery operator



Digital Compression Boosts Outdoor Condensing Unit Performance

Variable-capacity modulation maximizes energy savings, refrigeration reliability and installation flexibility



By Julie Havenar
Product Manager,
Condensing Units
Emerson



Precise temperature control and significant energy savings are now available with the Copeland™ Digital Outdoor Refrigeration Unit, X-Line Series. Building on the field-proven Copeland scroll compressor and X-Line outdoor condensing unit platforms, the digital X-Line Series delivers superior cooling and energy efficiency in small-format supermarkets, convenience stores and foodservice establishments — helping owners and operators to manage their refrigeration and food safety needs.

Digital modulation enables owners to maintain much more precise setting and tight control of case temperatures.

Maximize energy efficiencies and temperature precision

Digital Copeland scroll compression technologies enable continuous capacity modulation from 20 to 100 percent to deliver significant reductions in energy consumption and refrigeration improvements. Variable-capacity modulation allows the digital X-Line Series to deliver:

Energy efficiency advantages	Refrigeration reliability improvements
<ul style="list-style-type: none"> • Substantial annual energy efficiency improvements • Reduced compressor cycling • Longer equipment life • Decreased electrical load at startup 	<ul style="list-style-type: none"> • Precise setting and tight control over case temperatures • Load matching from 20 to 100 percent • Improved product integrity, which helps operators maximize food quality and safety



This helps operators minimize temperature deviations in refrigeration fixtures so that food is kept safe and at maximum quality. The digital X-Line Series combines compression technology with variable-speed fan motor control, large-capacity condenser coils, and smart protection and diagnostics to meet today's challenging refrigeration requirements.

Ideal for walk-in coolers and display cases, the digital X-Line delivers more precise, reliable refrigeration, longer-lasting equipment, and lower energy bills in medium-temperature applications.

Simply put, the digital X-Line is engineered for operators seeking to lower energy bills and manage food quality and safety.

Emerson Walk-In Solutions



X-Line Series Landing Page

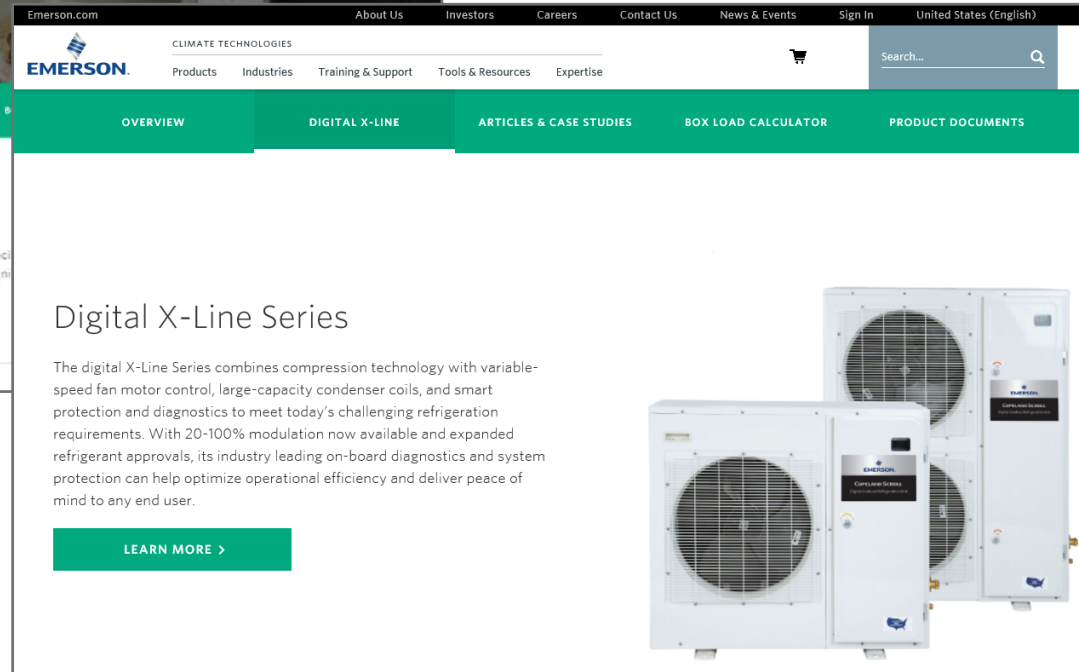
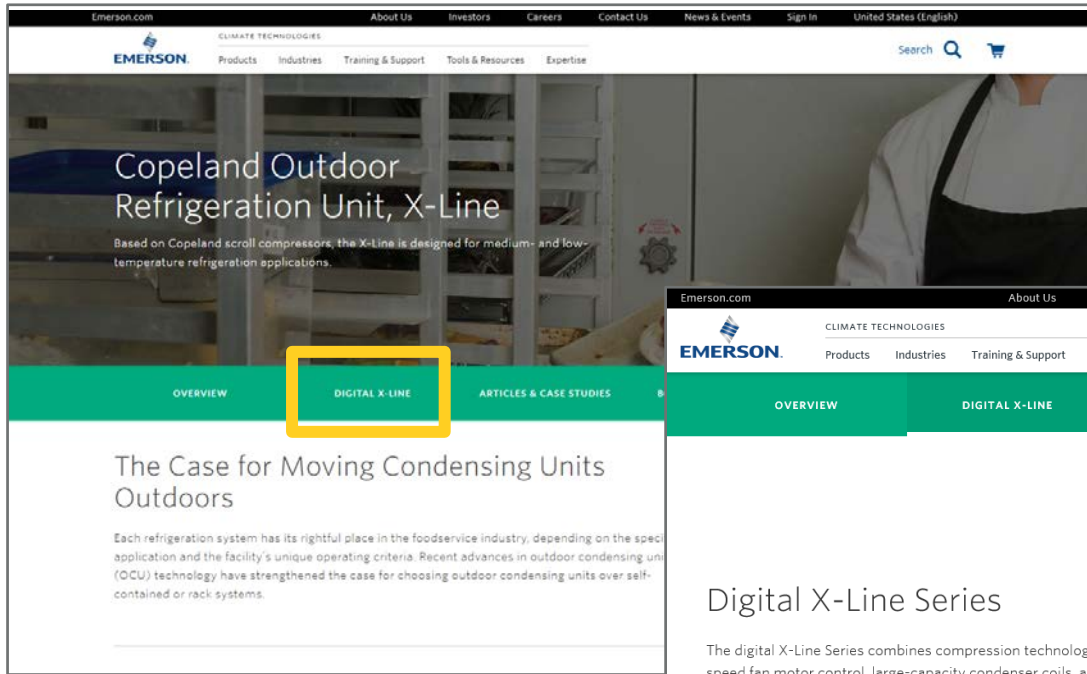

Brochures, manuals and QBRs

Emerson.com/CopelandOutdoorUnit



Thank You!

Questions?

DISCLAIMER

Although all statements and information contained herein are believed to be accurate and reliable, they are presented without guarantee or warranty of any kind, expressed or implied. Information provided herein does not relieve the user from the responsibility of carrying out its own tests and experiments, and the user assumes all risks and liability for use of the information and results obtained. Statements or suggestions concerning the use of materials and processes are made without representation or warranty that any such use is free of patent infringement and are not recommendations to infringe on any patents. The user should not assume that all toxicity data and safety measures are indicated herein or that other measures may not be required.